

Pump Maintenance Instruction -

DMC: PUMP-32-72-AA-00-00AA-520A-A

Language: en/US

Issue no: 001

Issue Date: 2012-01-24

Title: Pump Maintenance Instruction -

Security classification : Class01

Responsible partner company:

Originator:

Applicability:

QA: Unverified

Intentionally left blank

Pump Maintenance Instruction -

Table of Contents	Page
Preliminary Requirements.....	1
Procedure.....	2
List of Figures	Page
1	3
2	4

Preliminary Requirements

Required Conditions

Table 1 Required Conditions

Title	Data Module
None	

Support Equipment

Table 2 Support Equipment

Nomenclature	Identification No.	Qty	Remarks
None			

Consumables, Materials, and Expendables

Table 3 Consumables, Materials, and Expendables

Nomenclature	Identification No.	Qty	Remarks
None			

Spares

Table 4 Spares

Nomenclature	Identification No.	Qty	Remarks
None			

Safety Conditions

None

Procedure

- 1 Remove the Pump Valve Housing using number 15 wrench Fig. 1
- 2 Remove the Pump Valve Housing and inspect the rotors for cracks and fouling. Fig. 2
Replace as appropriate using Maintenance Procedure JC0346.
- 3 Prior to re-installation of the Pump Valve Housing, ensure the gasket is resealed with the correct gasket sealant.
- 4 Reinstall the Pump Valve Housing.
- 5 Reinstall the Pump Valve.

Note

Ensure that all bolts are tightened to 25nm.

- 6 Loosen the pump adjuster by .5 turn.

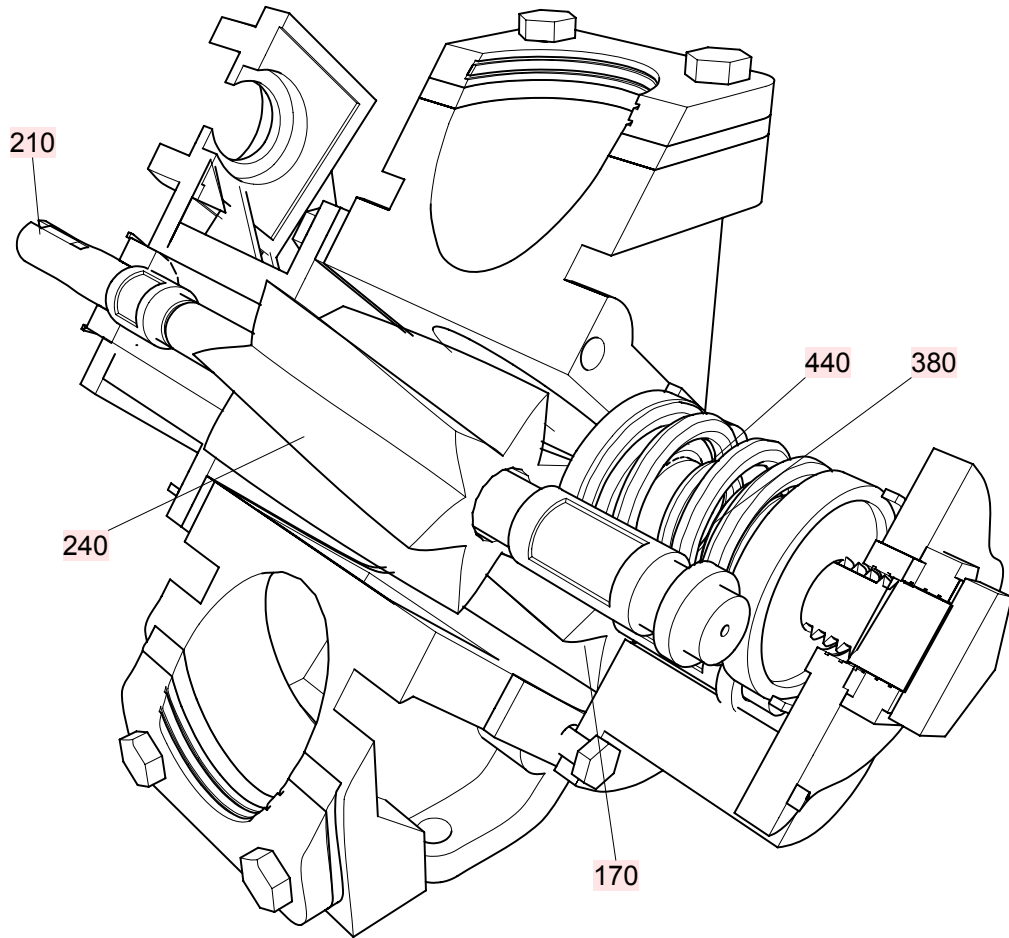

Figure 1



Figure 2

Required Conditions

Table 5 Required Conditions

Title	Data Module
None	

Intentionally left blank